

## Linear actuator DSZY1-Encoder

Electric linear actuators are used in many different applications.

DSZY1-encoder is equipped with a rugged acme screw with high static force. It is a small, compact and lightweight dc-linear drive.

Internal diodes allow the easy change of direction by reversing the power-supply. All DSZY1-actuators have two end-switches integrated ( not possible to adjust ).

An overload-protection can be made by using a current control.



### Model code

DSZY1	-	12	-	10	-	200	-	HS2 - IP65
Type		Voltage		Gear reduction		Stroke		Encoder and protection type
		12V		5		25mm		
		24V		10		50mm		
				20		100mm		
				30		150mm		
				40		200mm		
						250mm		
						300mm		

### Diagram

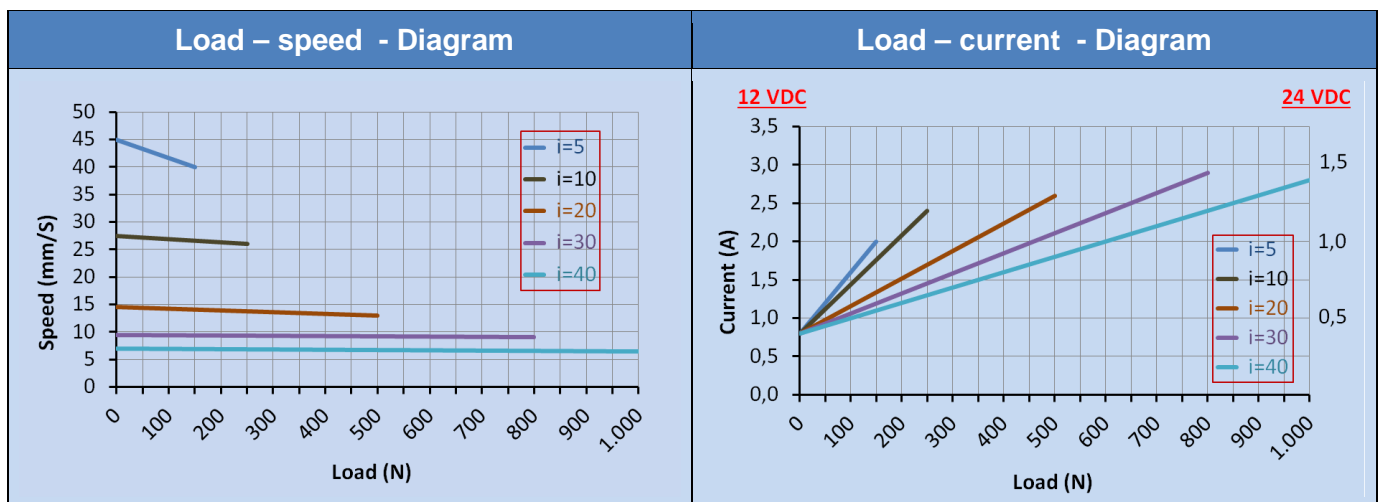



### Additional technical data

- push/pull force: up to 1000N
- static force: 2000N (by i=40)
- Operating temperature: -26C° - 65C°
- Duty cycle: 25% (1min continuous operation in 4min)
- Zinc alloy housing
- Aluminium outer tube and stroke rod
- Voltage: 12 or 24 VDC
- hall sensors
- Protection type: IP65

## Dimension

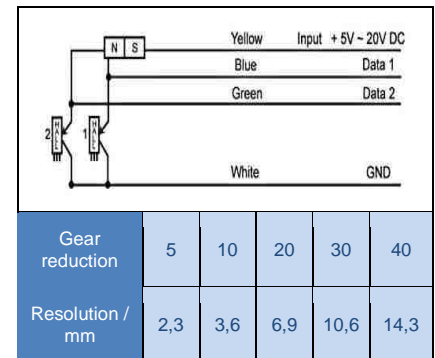
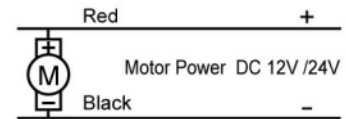
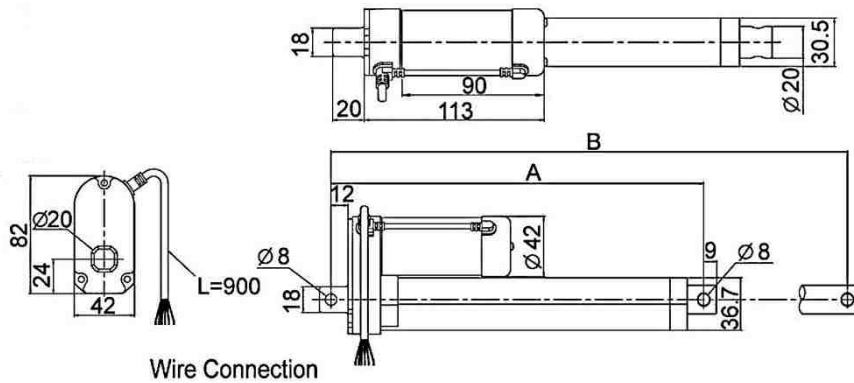
Linear actuator	length	mass in mm						
	stroke	25	50	100	150	200	250	300
DSZY1 - type Encoder	A	128	158	209	260	311	362	413
	B	153	208	309	410	511	612	713





C1x Hole  $\varnothing 8$   
C1x – is standard



$\varnothing 8$  C2x Plastic Connector  
**Options:** C2x or C3x



$\varnothing 8$  C3x Universal Joint  
**Attention:**  
By C3x - the dimension A and B lengthens itself about +41mm

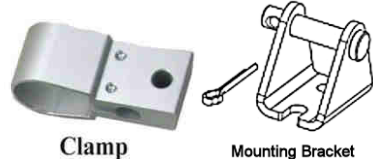

Clamp      Mounting Bracket

**Mounting für actuator**  
 Clamp: DSZY1-H01  
 Mounting Bracket: DSZY1-H02  
**Please additionally order.**

## Mounting instruction

Please make sure, that load is not bigger than shown in the diagram speed/load. If overload is possible in the application, please use a separate current control to switch off at too high current (= too high load). Nominal current, depending on ratio, is shown in the diagram current / load.

Please use the right voltage supply as it is shown on the actuator. For extending the piston rod connect the red cable with plus and the black cable with minus. Movement is stopped automatically at the end of the stroke. For moving back, reverse the polarity (change plus and minus). Endswitches are not adjustable by themselves.

Load should be centered in moving direction, shear forces should be avoid because of shortening the lifetime. Big shear forces can destroy the actuator! Be carefull.

	<b>Drive-System Europe Ltd.</b>	<a href="http://www.drive-system.com">www.drive-system.com</a> <a href="mailto:engineering@drive-system.com">engineering@drive-system.com</a>
---	---------------------------------	--